



Ko'p tezlikli motorlar uchun qutblar nisbati 8/4 bo'lgan qutblar soni o'zgaruvchan chulg'am ishlab chiqish

Hayotullo G. Magdiyev

PhD, kat.o'q., Toshkent davlat texnika universiteti, Toshkent, 100095, O'zbekiston; zhmagdiyev@gmail.com
<https://orcid.org/0000-0002-0478-8582>

Dolzarbli: hozirgi kunda ko'p tezlikli motorlarda qo'llaniladigan qutblar soni o'zgaruvchan chulg'amlarni tahlil qilish shuni ko'rsatadiki, ko'plab ishlab chiqilgan qutblar soni o'zgaruvchan chulg'am sxemalarida chiqish guruhlari hamda uzib-ulash kontaktlari soni ko'pligi, elektromagnit xususiyatlarining yaxshi emasligi va tayyorlashda turli qadamda turli shaxobchalardan foydalanish tufayli murakkab ishlab chiqarish texnologiyasi ularni amaliyotda keng miqyosda qo'llashga imkon bermaydi. Shu sababli, ushbu turdagi mashinalarning xususiyatlarini yaxshilashga qaratilgan tadqiqotlar muhim ahamiyat kasb etadi. Shuning uchun zamonaviy elektrotexnika talablariga javob beradigan qutblar soni o'zgaruvchan chulg'amlarni ishlab chiqish dolzarb masala bo'lib qolmoqda.

Maqsad: elektromagnit xossalari mavjud chulg'amlarga qaraganda yaxshilangan hamda qutblar nisbati 8/4 bo'lgan qutblar soni o'zgaruvchan chulg'am ishlab chiqish.

Usullari: qutblar nisbati 8/4 bo'lgan qutblar soni o'zgaruvchan chulg'am "Diskret berilgan fazoviy funksiyalar" usuli asosida ishlab chiqiladi.

Natijalar: ventilyator elektr yuritmasi motorlarining havo oralig'idagi magnit induksiylarining nisbatli qiymatini 1 ga yaqinlashtirish va $p=4$ qutb tomonida chulg'am koeffitsiyentini oshirish.

Kalit so'zlar: ko'p tezlikli motorlar, qutblar soni o'zgaruvchan chulg'am, magnit induksiya, chulg'am koeffitsiyenti, magnitlovchi kuch chiziqlar, chulg'am qadami.

Разработка полюсопереключаемой обмотки с соотношением полюсов 8/4 для многоскоростных двигателей

Хаётулло Г. Магдиев

PhD, ст.пр., Ташкентский государственный технический университет, Ташкент, 100095, Узбекистан; zhmagdiyev@gmail.com <https://orcid.org/0000-0002-0478-8582>

Актуальность: в настоящее время анализ полюсопереключаемых обмоток, применяемых в многоскоростных двигателях, показывает, что во многих разработанных схемах таких обмоток большое количество выводов группа и переключающих контактов, неудовлетворительные электромагнитные свойства и сложная технология производства, вследствие использования различных шагов и разных веток при изготовлении не позволяют широко применять их на практике. Поэтому исследования, направленные на улучшение свойств машин данного типа, имеют важное значение. В связи с этим полюсопереключаемых обмоток, соответствующих современным требованиям электротехники, остаётся актуальной задачей.

Цель: разработка полюсопереключаемой обмотки с соотношением полюсов 8/4 и улучшенными электромагнитными свойствами по сравнению с существующими обмотками.

Методы: полюсопереключаемой обмотки с соотношением полюсов 8/4 разрабатывается на основе метода «Дискретно заданных пространственных функций».

Результаты: приблизить отношения магнитных индукций в воздушном зазоре двигателей вентиляторного электропривода к 1 и увеличить коэффициент обмотки со стороны полюсов $p=4$.

Ключевые слова: многоскоростные двигатели, полюсопереключаемой обмотки, магнитная индукция, коэффициент обмотки, линии намагничивающей силы, шаг обмотки.

Development of a pole-changeable winding with a pole ratio of 8/4 for multi-speed motors

Hayotullo G. Magdiyev

PhD., sen.lec., Tashkent State Technical University, Tashkent, 100095, Uzbekistan; zhmagdiyev@gmail.com
<https://orcid.org/0000-0002-0478-8582>

Relevance: At present, the analysis of pole-changing windings used in multi-speed motors shows that in many developed circuits of such windings, a large number of output groups and switching contacts, unsatisfactory electromagnetic properties and complex production technology, due to the use of different steps and different branches in manufacturing do not allow them to be widely used in practice. Therefore, research aimed at improving the properties of machines of this type is of great importance. In this regard, pole-changing windings that meet modern

For citation: H.G. Magdiyev. Development of a pole-changeable winding with a pole ratio of 8/4 for multi-speed motors. Scientific and technical journal of Problems of Energy and Sources Saving, 2025, no. 2, pp. 162-168.

<https://doi.org/10.5281/zenodo.16941951>

Received: 10.01.2025
Revised: 14.03.2025
Accepted: 27.05.2025
Published: 27.06.2025

Copyright: © Hayotullo G. Magdiyev, 2025. Submitted to Problems of Energy and Sources Saving for possible open access publication under the terms and conditions of the Creative Commons Attribution (CC BY) license (<https://creativecommons.org/licenses/by/4.0/>).

electrical engineering requirements remains an urgent task.

Aim: development of a pole-changing winding with a pole ratio of 8/4 and improved electromagnetic properties compared to existing windings.

Methods: the pole-changing winding with a pole ratio of 8/4 developed based on the method of “Discretely specified spatial functions”.

Results: bring the ratio of magnetic inductions in the air gap of the fan electric drive motors closer to 1 and increase the winding coefficient on the pole side $p=4$.

Keywords: multi-speed motors, pole-changing winding, magnetic induction, winding coefficient, lines of magnetizing force, winding pitch.

1. Kirish (Introduction)

Hozirgi kunda mavjud «Y/YY» va Δ/YY bazaviy sxemalaridagi qutblar soni o‘zgaruvchan chulg‘amlarda havo oralig‘idagi magnit induksiyaalarining (B_2/B_1) nisbati 1 dan sezilarli darajda farqli bo‘lganligi uchun elektr motor aktiv qismidan to‘liq foydalanishga imkon bermaydi.

Masalan, liftlar va yuk ko‘tarish transport mexanizmlarida qutblar nisbati katta (1/4, 1/5, 1/6 va hk) bo‘lgan chulg‘amlardan foydalaniladi. Ushbu motorlarning havo oralig‘idagi magnit induksiyaning mosligini yaxshilash uchun “qo‘shimcha shaxobchali Y/YY” chulg‘am bazaviy sxemasi qo‘llaniladi [4,5] va qo‘shimcha shaxobchalar katta qutb tomonida ya‘ni $2p_1$ qutb tomonida joylashtiriladi.

Ma‘lumki, ventilyator elektr yuritmasi iste‘mol qilayotgan quvvati aylanishlar soni o‘zgarishiga kubik bog‘lik bo‘ladi. Shuning uchun elektr motorni aktiv qismidan ayniqsa kichik qutb tomonidan to‘liq foydalanish maqsadga muvofiq bo‘ladi. Ushbu elektr motorlarda havo oralig‘idagi magnit induksiyaalarining nisbatini 1 ga yaqinlashtirish va kichik qutb tomonida chulg‘am koeffitsiyentini oshirish uchun qo‘shimcha shaxobchalar kichik qutb tomonida joylashtirish maqsadga muvofiq bo‘ladi. Bunda havo oralig‘idagi magnit induksiyaalarining (B_2/B_1) nisbati sezilarli darajada o‘zgaradi [6,7] va 1 ga yaqinlashadi, kichik qutb tomonidagi quvvat 20-30% oshadi.

BO-06-300 tipidagi o‘q chiziqli ventilyatorlarning aylanish qismi elektr motorini stator pazlar soni 36 ga teng bo‘lib [5], ushbu elektr motor uchun uchta tezlikni hosil qiluvchi qutblar nisbati $2p_1/2p_2=8/4$ (aylanish tezligi 1500/750 ayl/min) bo‘lgan qutblar soni o‘zgaruvchan chulg‘am va $2p_1=6$ (aylanish tezligi 1000 ayl/min) bo‘lgan mavjud chulg‘am ishlab chiqish jarayonini ko‘rib chiqamiz.

2. Usullar va materiallar (Methods and materials)

Qutblar soni o‘zgaruvchan chulg‘amni qurish. Elektromagnit va texnologik xossalari bo‘yicha an‘anaviy chulg‘amlarga yaqin bo‘lgan qutblar soni o‘zgaruvchan chulg‘am sxemalarini “Diskret berilgan fazoviy funksiyalar” (DBFF) usuli yordamida olish mumkin. Boshqa usullardan farqli shundaki, bir qutb tomonida bazi g‘altaklardagi toklarning yo‘nalishi teskari o‘zgartirish orqali olinadi. Bu usul yangi prinsipga asoslangan bo‘lib, juft qutblar soni p_1 va p_2 , fazalar esa m_1 va m_2 bo‘lgan oddiy konstruksiyali ikkita ikki qatlamli sirtmoqsimon chulg‘am olinib, bir vaqtning o‘zida ikki tezlikli chulg‘amni loyihalash jarayonida qo‘llaniladi. Bunda chulg‘am uzib-ulash sxemasi tayyor holda qabul qilinmaydi, balki uni qurish jarayonining o‘zida shakllantiriladi yoki har bir qutb uchun motorning pazlari bo‘ylab faza toklarini taqsimlash va uyg‘unlashadigan chulg‘am fazalarini birlashtirish hisobga olingan holda oldindan ma‘lum bo‘lgan bazaviy sxemalardan tanlanadi [12].

Odatiy chulg‘amning diskret elementlari elektr motor stator pazlaridagi elektr o‘tkazgichlarning asosiy holati hisoblanadi va fazalarga bo‘linib ushbu faza bilan bir xil belgilangan bir shartli elektr o‘tkazgich bilan beriladi. Misol tariqasida quyidagicha bo‘lishi mumkin. Agar $2p_1$ qutbli chulg‘am (a, b va c) mos ravishda A, B va C fazalariga tegishli bo‘lgan stator pazlaridagi musbat birlik tokni shartli o‘tkazgichi bo‘lsa, $2p_2$ qutbli chulg‘am ($-d, -e$ va $-f$) esa D, E va F fazalariga tegishli bo‘lgan manfiy birlik tokni shartli o‘tkazgichidir [8].

Qutblar soni o‘zgaruvchan chulg‘am oddiy sxemalarga emas balki maxsus bazaviy sxemalarga (BS) quriladi, ular bir nechta guruhli chiqishlarga ega va manbaga ma‘lum ketma-ketlikda ulanadi (1-rasm).

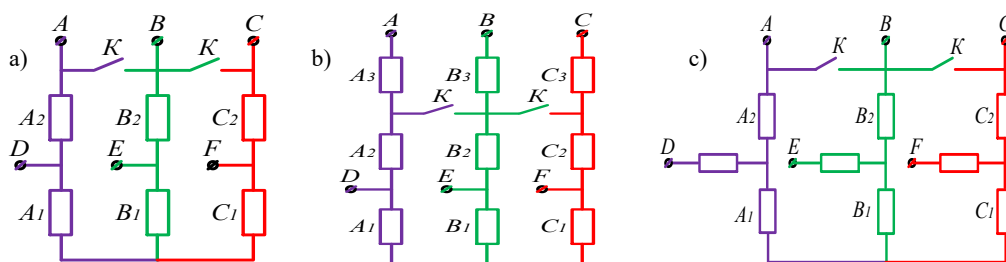

1-rasm. Qutblari o‘zgaruvchan chulg‘amning bazaviy sxemalari: a) Y/YY; b) va c) qo‘shimcha shaxobchali Y/YY;

Fig.1. Basic schemes of a pole-changing winding: a) Y/YY; b) and c) Y/YY with additional branch;



Talab etilgan standart pazlari soni va qutblar nisbati aniqlangandan so'ng bazaviy sxema qabul qilinadi va QSO'CH qurish quyidagi tartibda amalga oshiriladi [8, 12]:

1. Birinchi qatorga katta qutbga mos ya'ni qutblar nisbatining m -zonali yoki $2m$ -zonali chulg'amni (boshlangich chulg'am) birinchi qatlamining DBFF yoziladi;

2. Ikkinchi qatorga kichik qutbga mos ya'ni qutblar nisbatining $2m$ -zonali chulg'amni (bazaviy chulg'am) birinchi qatlamining DBFF yoziladi;

3. Agar qo'shimcha shaxobchalar bo'lsa ularni soni aniqlanadi va uchinchi qatorga tegishli pazlarga nol qiymat bilan yoziladi;

4. Birinchi va ikkinchi qator faza o'tkazgichlari holati taqqoslanib, uchinchi qatorning tegishli pazlarga modulyatsiyalangan chulg'amning kichik qutbga mos keluvchi o'tkazgichlar yoziladi.

Chulg'amni birlashtirish. Demak, qutblar soni o'zgaruvchan chulg'amning $2p_1$ qutbli qismini qurish tartibi yuqorida keltirilgan qoidalardan kelib chiqqan holda [1], har bir pazdagi tok holatlarini ketma-ket ko'rib chiqish va sintezlanuvchi chulg'am DBFF ni yozishdan iborat (1-jadval).

1-jadval. $2p_1=8$ qutbli chulg'amni sintezlash

Table 1. Synthesis of a $2p_1=8$ -pole winding

1	2	3	4	5	6	7	8	9	10	11	12	13	14	15	16	17	18	19	20	21	22	23	24	...	36	Pazlar
x	a	a	x	b	b	x	c	c	x	a	a	x	b	b	x	c	c	x	a	a	x	b	b	...	c	$p_1=4$
d	d	d	<u>e</u>	<u>e</u>	<u>e</u>	f	f	f	<u>d</u>	<u>d</u>	<u>d</u>	e	e	e	<u>f</u>	<u>f</u>	<u>f</u>	d	d	d	<u>e</u>	<u>e</u>	<u>e</u>	...	<u>f</u>	$p_2=2$
x	a	a	x	b	b	x	c	c	x	a	a	x	b	b	x	c	c	x	a	a	x	b	b	...	c	$p_1=4$

Yuqorida sintezlash natijasida olingan chulg'amni "qo'shimcha shaxobchali Y/YY" chulg'am bazaviy sxemasiga moslashtiriladi [1,2,3] va qo'shimcha shaxobchali chiqarilgan g'altaklar o'rniga (x) belgisi qo'yiladi. Shundan so'ng sintezlangan chulg'am va past qutb tomon chulg'amlarin birlashtiriladi (2-jadval).

2-jadval. G'altaklarni qo'shimcha shaxobchalarga chiqishini hisobga olgan holda quyi qatlamlarning DBFF

Table 2. DSF of the lower layers, taking into account the exit of the coils to additional branches

1	2	3	4	5	6	7	8	9	10	11	12	13	14	15	16	17	18	19	20	21	22	23	24	...	36	Pazlar
x	a	a	x	b	b	x	c	c	x	a	a	x	b	b	x	c	c	x	a	a	x	b	b	...	c	$p_1=4$
d	d	d	<u>e</u>	<u>e</u>	<u>e</u>	f	f	f	<u>d</u>	<u>d</u>	<u>d</u>	e	e	e	<u>f</u>	<u>f</u>	<u>f</u>	d	d	d	<u>e</u>	<u>e</u>	<u>e</u>	...	<u>f</u>	$p_2=2$

Aytib o'tish joizki, $2p_1=8$ qutb tomonda, ya'ni asosiy tezlikda qadamni to'g'ri tanlash orqali qatamlarni juda muvaffaqiyatli o'zaro mosligi va magnitlovchi kuch chiziqlari shakl jihatidan sinusoidaga yaqinligiga erishish mumkin. 3-jadvalda qutblari soni o'zgaruvchan chulg'amni $2p_1=8$ qutb tomon uchun $\gamma=5$ qadamda yuqori va quyi qatlamlari DBFFlari ko'rsatilgan [12].

3-jadval. $2p_1=8$ qutb tomon uchun DBFF

Table 3. DSF for $2p_1=8$ pole side

1	2	3	4	5	6	7	8	9	10	11	12	13	14	15	16	17	18	19	20	21	22	23	24	...	36	Pazlar
x	a	a	x	b	b	x	c	c	x	a	a	x	b	b	x	c	c	x	a	a	x	b	b	...	c	$p_1=4$
<u>b</u>	<u>b</u>	x	<u>c</u>	<u>c</u>	x	<u>a</u>	<u>a</u>	x	<u>b</u>	<u>b</u>	x	<u>c</u>	<u>c</u>	x	<u>a</u>	<u>a</u>	x	<u>b</u>	<u>b</u>	x	<u>c</u>	<u>c</u>	x	...	x	

Ushbu 4-jadvalda qutblar soni o'zgaruvchan chulg'amni $2p_2=4$ qutb tomon uchun chulg'am qadami $\gamma=5$ bo'lgan holatida yuqori va quyi qatlam DBFF lari ko'rsatilgan.

4-jadval. $2p_2=4$ qutb tomon uchun DBFF

Table 4. DSF for $2p_2=4$ pole side

1	2	3	4	5	6	7	8	9	10	11	12	13	14	15	16	17	18	19	20	21	22	23	24	...	36	Pazlar
d	d	d	<u>e</u>	<u>e</u>	<u>e</u>	f	f	f	<u>d</u>	<u>d</u>	<u>d</u>	e	e	e	<u>f</u>	<u>f</u>	<u>f</u>	d	d	d	<u>e</u>	<u>e</u>	<u>e</u>	...	<u>f</u>	$p_2=2$
<u>e</u>	<u>e</u>	f	f	f	<u>d</u>	<u>d</u>	<u>d</u>	e	e	e	<u>f</u>	<u>f</u>	<u>f</u>	d	d	d	<u>e</u>	<u>e</u>	<u>e</u>	f	f	f	<u>d</u>	...	<u>e</u>	

Olingan DBFF ga muvofiq fazalarni birlashtirish jadvali yordamida (5-jadval) g'altaklarni shaxobcha bo'ylab taqsimlanish jadvalini olish va qutblari o'zgaruvchan chulg'am ulanish sxemasini tuzish mumkin. Birinchi faza uchun $A1, A2, A3$, ikkinchi faza uchun $B1, B2, B3$, uchinchi faza uchun $C1, C2, C3$, 2.8-jadvalda uzib-ulash sxemasining shaxobchalari bo'ylab qutblari soni o'zgaruvchan chulg'am g'altaklari taqsimlanishi holati ko'rsatilgan[3].

5-jadval. Qo'shimcha shaxobchali "Y/YY" sxemasida chulg'am shaxobchalari jadvali
Table 5. Table of branch offices in the "Y/YY" scheme with additional branches

Shaxobcha nomi	G'altak raqami	Shaxobcha nomi	G'altak raqami	Shaxobcha nomi	G'altak raqami
$A1$	11, 12, 29, 30	$B1$	5, 6, 23, 24	$C1$	17, 18, 35, 36
$A2$	1, -10, 19, -28	$B2$	13, -4, 31, -22	$C2$	7, -16, 25, -34
$A3$	2, 3, 20, 21	$B3$	14, 15, 32, 33	$C3$	8, 9, 26, 27

2-rasmda qutblari nisbati 8/4 bo'lgan uch fazali qutblari o'zgaruvchan chulg'amning elektr sxemasi keltirilgan bo'lib chulg'am g'altaklari "qo'shimcha shaxobchali yulduz - juft yulduz" sxemaga guruhlashtirilib bajarilgan. Bunda $A1$ qismda 11-, 12-, 29-, 30-, tartib raqamli g'altaklar mos ravishda ketma-ket ulangan, $A2$ qismi ikkiga bo'linib $A2.1$ qismi 1-, 10-, bilan $A2.2$ qismi 19-, 28-, g'altaklar bir biriga parallel ulangan, $A3$ qismda 2-, 3-, 20-, 21-, tartib raqamli g'altaklar mos ravishda ketma-ket ulangan, $B1$ qismda 5-, 6-, 23-, 24-, tartib raqamli g'altaklar mos ravishda ketma-ket ulangan, $B2$ qismi ikkiga bo'linib $B2.1$ qismi 13-, 4-, bilan $B2.2$ qismi 31-, 22-, g'altaklar bir biriga parallel ulangan, $B3$ qismda 14-, 15-, 32-, 33-, tartib raqamli g'altaklar mos ravishda ketma-ket ulangan, $C1$ qismda 17-, 18-, 35-, 36-, tartib raqamli g'altaklar mos ravishda ketma-ket ulangan, $C2$ qismi ikkiga bo'linib $C2.1$ qismi 7-, 16-, bilan $C2.2$ qismi 25-, 34-, g'altaklar bir biriga parallel ulangan, $C3$ qismda 8-, 9-, 26- 27-, tartib raqamli g'altaklar mos ravishda ketma-ket ulangan [3,9,10].

Uch fazali elektr ta'minlash manbasi A, B, C chiqishlarga ulanganda (bunda D, E, F chiqishlar ochiq, kontaktorni kontaktlari uzilgan), havo oralig'ida sakkiz qutbli aylanuvchi magnit to'liqini hosil bo'ladi, sxemada 24 ta g'altak ulangan, har bir fazani EYUK vektorlari amplituda bo'yicha teng va faza bo'yicha 120° burilgan, ya'ni chulg'amning $2p_2=8$ qutb tomoni uchun ta'minot manbaiga nisbatan mutlaqo simmetrik [3] bo'ladi.

Uch fazali elektr ta'minlash manbasi D, E, F chiqishlarga ulanganda (bunda A, B, C chiqishlar ochiq, kontaktorni kontaktlari o'zaro qo'shilgan), havo oralig'ida olti qutbli aylanuvchi magnit to'liqini hosil bo'ladi, sxemada 36 ta g'altak ulangan, har bir fazani EYUK vektorlari amplituda bo'yicha teng va faza bo'yicha 120° burilgan, ya'ni chulg'amning $2p_1=4$ qutb tomoni uchun ta'minot manbaiga nisbatan mutlaqo simmetrik bo'ladi[3].

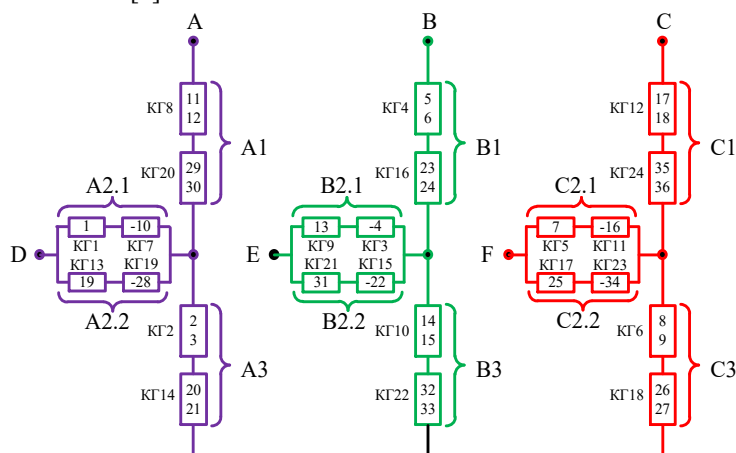

2-rasm. Qutblari nisbati 8/4 bo'lgan QSO'CH elektr sxemasi

Fig.2. Electrical diagram of a PCHW with a pole ratio of 8/4

Bu yerda, qo'shimcha shaxobchali "Y/YY" BS asosida stator pazlari soni 36 ga teng, juft qutblari nisbati 8/4 va chulg'am qadami $\gamma=5$ bo'lgan taklif etilayotgan va kengaytirilgan elektr sxemasi keltirilgan. «A» chiqishi 11-g'altaklarning boshidan chiqarilgan, «B» chiqishi 5- g'altaklarning boshidan chiqarilgan, «C» chiqishi 17- g'altaklarning boshidan chiqarilgan [3,11,12] hamda «D» chiqishi 19-g'altakning oxiri va 1-g'altakning boshini ulanish nuqtasidan chiqarilgan.

Birinchi, BS asosida ishlab chiqilayotgan QSO'CH va BS shoxobchalari tok o'tkazgichlari

o'rtasida aniq yoki karrali mos kelish shartlari bajariladi, shundan so'ng BS shoxobchalari ulanishlariga mos ravishda tok o'tkazgichlar [9,10] elektr ulanishlarini amalga oshirish orqali QSO'CH sxemasi olinadi(3-rasm).

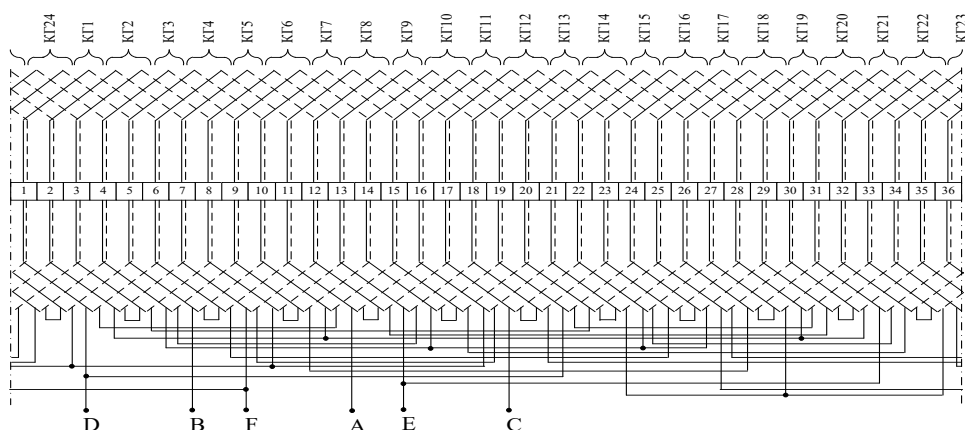

3-rasm. Qutblari nisbati 8/4 bo'lgan QSO'Ch ning kengaytirilgan elektr sxemasi

Fig.3. Extended electrical diagram of a PCHW with a pole ratio of 8/4

bu yerda, «E» chiqishi 13-g'altakning oxiri va 31-g'altakning boshini ulanish nuqtasidan chiqarilgan, «F» chiqishi esa 7-g'altakning oxiri va 25-g'altakning boshini ulanish nuqtasidan chiqarilgan. Shu bilan birga 21-33-27-g'altaklarning boshi esa bitta umumiy nuqtaga [3,6,7] birlashtiriladi. Juft yulduz sxemasini hosil qilish uchun chulg'am ikkita chap va ikkita o'ng chiqishi ega bo'lgan ikki qutbli uzib-ulagich bilan ta'minlanishi lozim.

3. Natijalar va muhokama (Results and discussion)

Uch tezlikli asinxron motor uchun ishlab chiqilgan qutblar soni o'zgaruvchan chulg'amni elektromagnit xususiyatlarini aniqlashda eng maqbul chulg'am qadami ya'ni chulg'am qadami $y=5$ bo'lganda $2p=8$, $2p=6$ va $2p=4$ qutbli tomonlar uchun magnit yurituvchi kuch chiziqlari shakli (4-rasm) keltirilgan. Magnit yurituvchi kuch chiziqlari shaklidan ko'rinishimiz mumkin, shakl uchta qutb tomon uchun ham ko'rinish jihatdan sinusoidaga yaqinlashgan va yuqori garmonikalar nisbatan kichik.

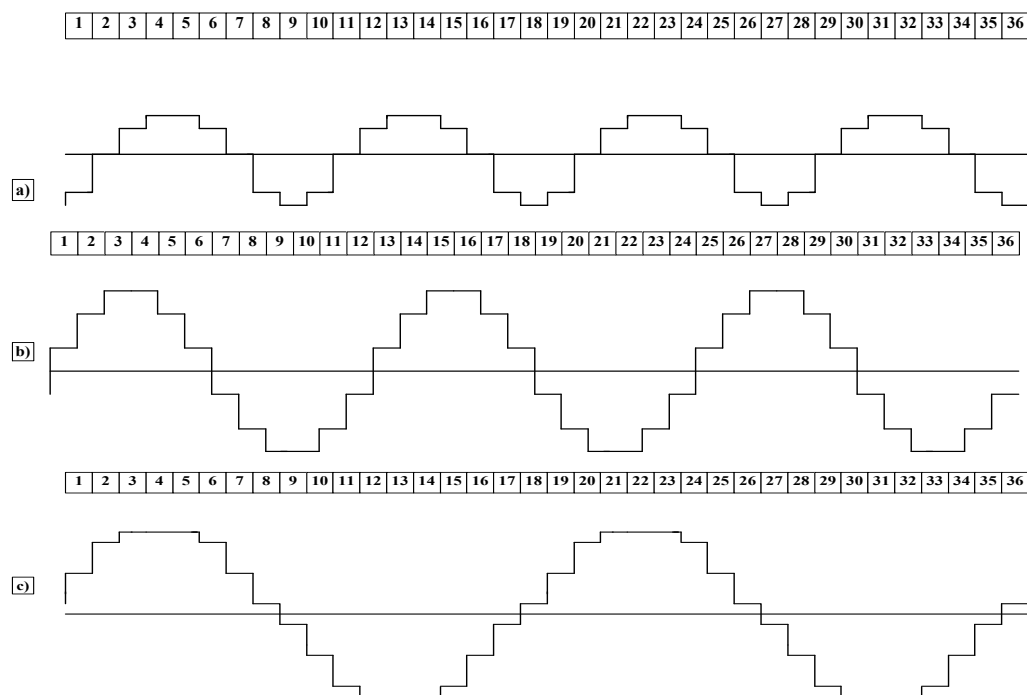

4-rasm. Chulg'am qadami $y=5$ bo'lganda magnitlovchi kuch chiziqlari shakli: a) $2p=8$ tomon b) $2p=6$ tomon c) $2p=4$ tomon

Fig.4. The shape of the magnetizing lines of force when the pulley step is $y=5$: a) $2p=8$ direction b) $2p=6$ direction c) $2p=4$ direction



Yangi ishlab chiqilgan qutblar soni o'zgaruvchan chulg'amni uchta qutb tomoni uchun ham chulg'am koeffitsiyenti va amplituda qiymati natijalari quyidagi 6÷8 jadvallarda keltirilgan. Chulg'am qadami $y=5$ bo'lganda $2p=8$, $2p=6$ va $2p=4$ qutbli tomonlar uchun chulg'am koeffitsiyenti mos ravishda $k_{chul1}=0.925$, $k_{chul2}=0.933$ va $k_{chul3}=0.735$ teng [3] bo'ladi.

6-jadval. $p_1=4$ tomon uchun chulg'am ma'lumotlari ($y=5$)

Table 6. the data for the side $p_1=4$ is the slope ($y=5$)

	"Y/YY" bazaviy sxema shaxobchasi								
	A1	A2	A3	B1	B2	B3	C1	C2	C3
A	14.81	14.81	14.81	14.81	14.81	14.81	14.81	14.81	14.81
k_{chul}	0.925	0.925	0.925	0.925	0.925	0.925	0.925	0.925	0.925
φ	70	170	50	70	170	50	70	170	50

7-jadval. $p_2=3$ tomon uchun chulg'am ma'lumotlari ($y=5$)

Table 7. the data for the side $p_2=3$ is the slope ($y=5$)

	"Y/YY" bazaviy sxema shaxobchasi		
	A	B	C
A	22.39	22.39	22.39
k_{chul2}	0.933	0.933	0.933
φ	0.00	120	120

8-jadval. $p_3=2$ tomon uchun chulg'am ma'lumotlari ($y=5$)

Table 8. the data for the side $p_3=2$ is the slope ($y=5$)

	"Y/YY" bazaviy sxema shaxobchasi		
	D	E	F
A	8.82	8.82	8.82
k_{chul3}	0.735	0,735	0,735
φ	20	140	100

Chulg'am qadami $y=5$ bo'lganda $2p=8$, $2p=6$ va $2p=4$ qutbli tomonlar uchun chulg'am koeffitsiyenti mos ravishda $k_{chul1}=0.925$, $k_{chul2}=0.933$ va $k_{chul3}=0.735$ teng bo'ladi. Natija sifatida aytish mumkinki, eng yaqin analogga nisbatan ushbu yangi qutblar soni o'zgaruvchan chulg'amning induksiyalar nisbati 19,1% ga yaxshilangan.

Xulosa (Conclusion)

Ushbu yangi ishlab chiqilgan qutblar soni o'zgaruvchan chulg'amni elektr mashinalarga qo'llash mashinaning aktiv qismidan samaraliroq foydalanishni oshirish, chulg'am misini tejash, izolyatsion materiallarni tejash va energetik ko'rsatkichlarni oshirish imkonini yaratadi. Shuningdek, og'irlik va o'lcham ko'rsatkichlarini ko'p tezlikli motorni oddiy bir tezlikli asinxron motorlarga yaqinlashtirishga imkon beradi. Diskret berilgan fazoviy funksiyalar usuli yordamida "qo'shimcha shaxobchali Y/YY" bazaviy sxemasi asosida qutblar nisbati 4:2 bo'lgan yuqori elektromagnit xususiyatlarga ega yangi qutblar soni o'zgaruvchan chulg'am ishlab chiqilgan. Natijada eng yaqin analogga nisbatan yangi qutblar soni o'zgaruvchan chulg'amning induksiyalar nisbati 19,1% ga yaxshilangan. Shuningdek, ushbu chulg'amni elektromagnit xususiyatlarini aniqlashda eng maqbul chulg'am qadami $y=5$ bo'lganda $2p=8$, $2p=6$ va $2p=4$ qutbli tomonlar uchun chulg'am koeffitsiyenti mos ravishda $k_{chul1}=0.925$, $k_{chul2}=0.933$ va $k_{chul3}=0.735$ teng bo'ladi.

ADABIYOTLAR

1. Бобожанов М.К. Электрические машины с полюспереключаемыми обмотками, используемые в целях энерго-и ресурсосбережение.: Дис. ... д-ра. техн. наук.- Ташкент, 2006. - 243 с.
2. Рисмухамедов Д.А. Полюспереключаемые асинхронные моторы для турбомеханизмов: Дисс. ... канд.техн. наук. - Ташкент, 2006. -225 с.
3. Bobojanov M.Q., Rismuxamedov D.A., To'ychiyev F.N., Magdiyev H.G'., Rismuxamedov S.D., Qutblari nisbati 8/4 bo'lgan uch fazali qutblari o'zgaruvchan chulg'am / O'zbekiston Respublikasi Adliya vazirligi huzuridagi intellektual mulk agentligi. Ixtiroga patent №IAP20210432, 30.08.2021 y.



4. Бобожанов М.К., Рисмухамедов Д.А., Туйчиев Ф.Н., Магдиев Х.Г. Экспериментальное исследование динамических режимов работы двухскоростных асинхронных электромоторей // Журнал "Вестник ТашГТУ". - Ташкент, 2019. - №2 (107). -С. 63-68.
5. Ванурин В.Н., Жидченко Т.В. .Алалнз схем обмоток многоскоростных электродвигателей для привода вентиляторных установок // Совершенствование процессов и технических средств в АПК. - Зерноград 2000. -С.81.87.
6. Рисмухамедов Д.А, Туйчиев Ф.Н., Шамсутдинов Х.Ф. Трехфазная полюсопереключаемая обмотка с соотношением пар полюсов 2/5 при 30 пазах статора. Патент на изобретения. № IAP 06203, 30.04.2020.
7. Попов В.И. Оценка электромагнитных свойств трех- и двухфазных обмоток электрических машин переменного тока // М.: Электротехника, 2001. - № 10. – С. 9-17.
8. Каримов. Х.Г., Тупогуз Ю.А. Метод построения электрически совмещенных обмоток переменного тока // М.: Электричество, 1987. - №9 – С. 29-38.
9. М.К. Bobojanov, D.Rismukhamedov, F.Tuychiev, Kh.F.Shamsutdinov, Kh.Magdiev. Pole-changing motor for lift installation // E3S Web of Conferences, 14 December 2020, Volume 216, 01164 (2020), doi.org/10.1051/e3sconf/202021601164
10. Рисмухамедов Д.А., Бобожанов М.К., Туйчиев Ф.Н., Шамсутдинов Х.Ф. Ганиев С.Т., Магдиев Х.Ф. Трехфазная полюсопереключаемая обмотка с соотношением пар полюсов 3/4 // Агентство по интеллектуальной собственности РесУз. Патент на изобретение IAP 06647, 29.11.2019.
11. Rismukhamedov D.A., Tuychiev F.N., and Magdiev Kh.G. Development and analysis of 5/6 pole-change winding for multi-speed motors // International Journal of Advanced Research in Science, Engineering and Technology, Volume 12, issue 2, 2025 (05.00.00 №2), pp. 22924-22930.
12. Шамсутдинов Х.Ф., Магдиев Х.Г. Разработка полюсопереключаемой обмотки методом методом дискретно-заданных пространственных функций // «Ўзбекистонда илмий-амалий тадқиқотлар» мавзусидаги Республика 15-қўп тармоқли илмий масофавий онлайн конференция. Тошкент, 2020 йил 30- апрел, №15 сон.

REFERENCES

1. Bobojanov M.K. Electric machines with pole-changing windings used for energy and resource conservation: Diss. ... Dr. of Engineering Sciences. - Tashkent, 2006. - 243 p.
2. Rismukhamedov D.A. Pole- changing asynchronous motors for turbomechanisms: Diss. ... Cand. of Engineering Sciences. - Tashkent, 2006. -225 p.
3. Bobojanov M.Q., Rismukhamedov D.A., To'ychiyev F.N., Magdiyev H.G., Rismukhamedov S.D., Three-phase with pole-changing windings a pole ratio of 8/4 / Intellectual Property Agency under the Ministry of Justice of the Republic of Uzbekistan. Patent for the invention No. IAP20210432, 30.08.2021.
4. Bobojanov M.K., Rismukhamedov D.A., Tuychiev F.N., Magdiev H.G. Experimental study of dynamic operating modes of two-speed asynchronous electric motors // Journal "Bulletin of TashSTU". - Tashkent, 2019. - No. 2 (107). - P. 63-68.
5. Vanurin V.N., Zhidchenko T.V. Analysis of winding schemes of multi-speed electric motors for driving fan units // Improving processes and technical means in the agro-industrial complex. - Zernograd 2000. - P.81.87.
6. Rismukhamedov D.A, Tuychiev F.N., Shamsutdinov H.F. Three-phase pole-switching winding with a pole pair ratio of 2/5 at 30 stator slots. Patent for inventions. No. IAP 06203, 30.04.2020.
7. Popov V.I. Evaluation of electromagnetic properties of three- and two-phase windings of AC electric machines // М.: Elektrotehnika, 2001. - No. 10. - P. 9-17.
8. Karimov. Kh.G., Tupoguz Yu.A. Method for constructing electrically combined AC windings // М.: Elektrichestvo, 1987. - No. 9 - P. 29-38.
9. М.К. Bobojanov, D.Rismukhamedov, F.Tuychiev, Kh.F.Shamsutdinov, Kh.Magdiev. Pole-changing motor for lift installation // E3S Web of Conferences, 14 December 2020, Volume 216, 01164 (2020), doi.org/10.1051/e3sconf/202021601164
10. Rismukhamedov D.A., Bobojanov M.K., Tuychiev F.N., Shamsutdinov Kh.F., Ganiev S.T., Magdiev Kh.G. Three-phase pole-change winding with a pole pair ratio of 3/4 // Intellectual Property Agency of the Republic of Uzbekistan. Patent for invention IAP 06647, November 29, 2019.
11. Rismukhamedov D.A., Tuychiev F.N., and Magdiev Kh.G. Development and analysis of 5/6 pole-change winding for multi-speed motors // International Journal of Advanced Research in Science, Engineering and Technology, Volume 12, issue 2, 2025 (05.00.00 No. 2), pp. 22924-22930.
12. Shamsutdinov Kh.F., Magdiev Kh.G. Development of a pole-switching winding using the method of discretely specified spatial functions // 15th Republican Multidisciplinary Scientific Distance Online Conference on "Scientific and Practical Research in Uzbekistan". Tashkent, April 30, 2020.